

Genie®



Operator's Manual *with Maintenance Information*

First Edition
Fourth Printing
Part No. 62756

S™-120

S™-125

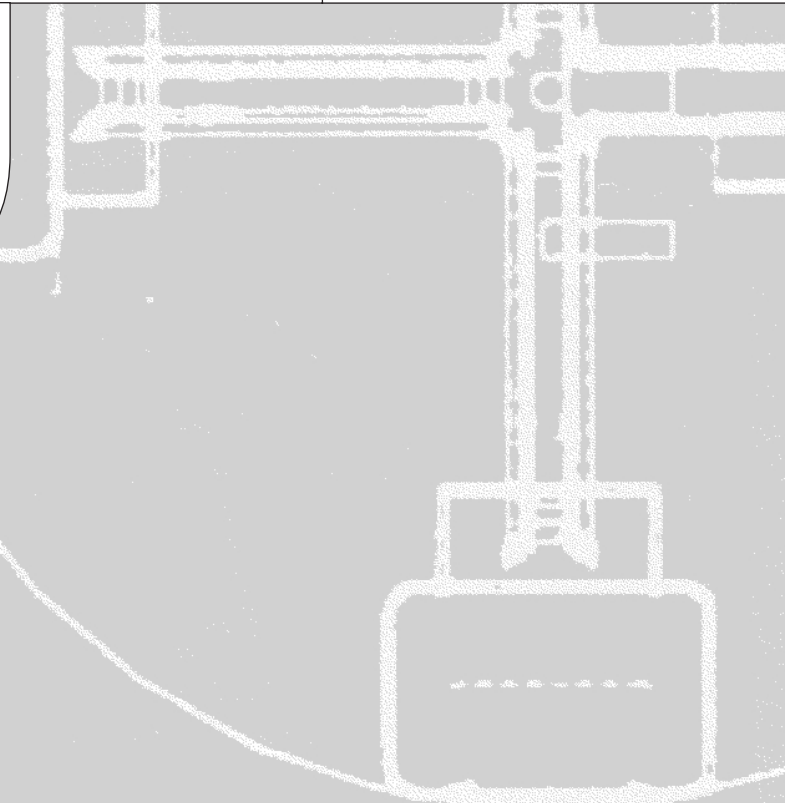

Important

Read, understand and obey these safety rules and operating instructions before operating this machine. Only trained and authorized personnel shall be permitted to operate this machine. This manual should be considered a permanent part of your machine and should remain with the machine at all times. If you have any questions, call Genie Industries.

Contents

	Page
Safety Rules	1
Controls	7
Pre-operation Inspection	10
Maintenance	12
Function Tests	15
Work Place Inspection	21
Operating Instructions	22
Transport	26
Decals	27
Specifications	29

Contact us:

Internet: <http://www.genielift.com>

E-mail: techpub@genieind.com

Genie Industries

Copyright © 2000 by Genie Industries

First Edition: First Printing, May 2000
 Second Printing, July 2000
 Third Printing, July 2000
 Fourth Printing, January 2001

"Genie" is a registered trademark of Genie Industries in the U.S.A. and many other countries. "S" is a trademark of Genie Industries.

These machines comply with ANSI/SIA 92.5-1992.

 Printed on recycled paper

Printed in U.S.A.

Safety Rules



Danger

Failure to obey the instructions and safety rules in this manual will result in death or serious injury.

Do Not Operate Unless:

- You learn and practice the principles of safe machine operation contained in this operator's manual.
 - 1 Avoid hazardous situations.**
 - Know and understand the above principle before going on to the next section.**
 - 2 Always perform a pre-operation inspection.
 - 3 Always perform function tests prior to use.
 - 4 Inspect the work place.
 - 5 Only use the machine as it was intended.
- You read, understand and obey:
 - Manufacturer's instructions and safety rules—safety and operator's manuals and machine decals
 - employer's safety rules and worksite regulations
 - applicable governmental regulations
- You** are properly trained to safely operate the machine.

SAFETY RULES

Electrocution Hazards

This machine is **not** electrically insulated and will **not** provide protection from contact with or proximity to electrical current.

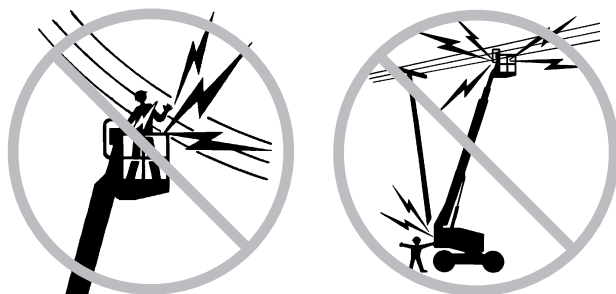

Maintain safe distances from electrical power lines and apparatus in accordance with applicable governmental regulations and the following chart.

Voltage Phase to Phase	Minimum Safe Approach Distance	
	Feet	Meters
0 to 300V	Avoid Contact	
300V to 50KV	10	3.05
50KV to 200KV	15	4.60
200KV to 350KV	20	6.10
350KV to 500KV	25	7.62
500KV to 750KV	35	10.67
750KV to 1000KV	45	13.72

Allow for platform movement, electrical line sway or sag and beware of strong or gusty winds.

Keep away from the machine if it contacts energized power lines. Personnel on the ground or in the platform must not touch or operate the machine until energized power lines are shut off.

Do not use the machine as a ground for welding unless the machine is equipped with the weld line to platform option and it is properly connected.

Tip-over Hazards

Occupants and equipment shall not exceed the maximum platform capacity.

Maximum platform capacity		
S-120	750 lbs	340 kg
S-125	500 lbs	227 kg
Maximum occupants		2

Do not raise or extend the boom unless the machine is on a firm, level surface.

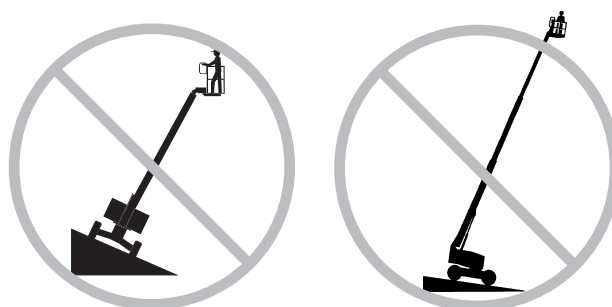

Do not depend on the tilt alarm as a level indicator. The tilt alarm sounds in the platform only when the machine is on a severe slope.

SAFETY RULES

If the tilt alarm sounds:

Do not extend, rotate or raise the boom above horizontal. Move the machine to a firm, level surface before raising the platform. If the tilt alarm sounds when the platform is raised, use extreme caution to retract the boom and lower the platform. Do not rotate the boom while lowering. Move the machine to a firm, level surface before raising the platform.

Do not use the platform controls to free a platform that is caught, snagged or otherwise prevented from normal motion by an adjacent structure. All personnel must be removed from the platform before attempting to free the platform using the ground controls.

Do not operate the machine in strong or gusty winds. Do not increase the surface area of the platform or the load. Increasing the area exposed to the wind will decrease machine stability.



Use extreme care and slow speeds while driving the machine in stowed position across uneven terrain, debris, unstable or slippery surfaces and near holes and drop-offs.

Do not drive the machine on or near uneven terrain, unstable surfaces or other hazardous conditions with the boom raised or extended.

Maximum allowable side force - ANSI & CSA	150 lbs 667 N
Maximum allowable side force - CE	90 lbs 400 N

Do not push off or pull toward any object outside of the platform.

Do not alter or disable machine components that in any way affect safety and stability.

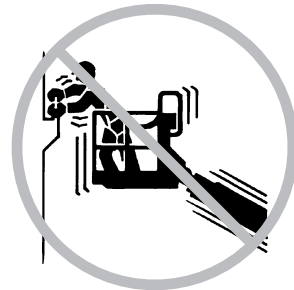

Do not replace items critical to machine stability with items of different weight or specification.

Do not modify or alter an aerial work platform. Mounting attachments for holding tools or other materials onto the platform, toeboards or guard rail system can increase the weight in the platform and the surface area of the platform or the load.

SAFETY RULES

Do not place or attach overhanging loads to any part of this machine.

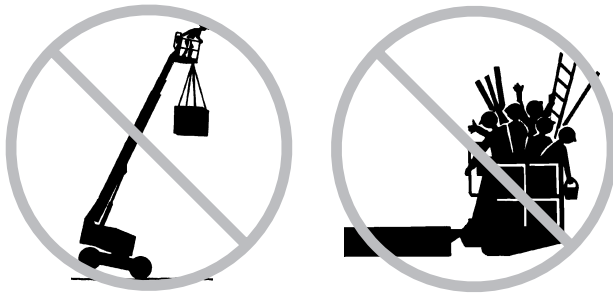

Do not sit, stand or climb on the platform guard rails. Maintain a firm footing on the platform floor at all times.

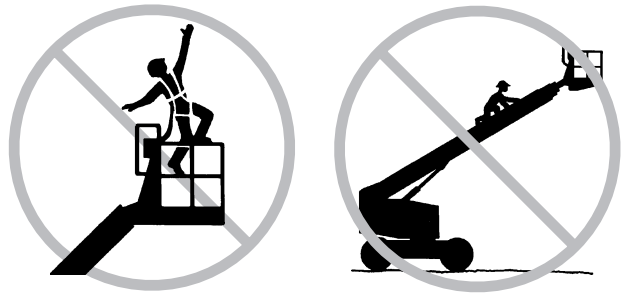

Do not place ladders or scaffolds in the platform or against any part of this machine.

Do not use the machine on a moving or mobile surface or vehicle.

Be sure all tires are in good condition and lug nuts are properly tightened.

Do not climb down from the platform when raised.

Keep the platform floor clear of debris.

Lower the platform entry mid-rail or close the entry gate before operating.

Fall Hazards



Occupants must wear a safety belt or harness in accordance with governmental regulations. Attach the lanyard to the anchorage point provided in the platform.

It is recommended that operators wear an approved hard hat when operating the machine.

Collision Hazards



Be aware of limited sight distance and blind spots when driving or operating.

Be aware of boom position and tailswing when rotating turntable.

Check work area for overhead obstructions or other possible hazards.



Be aware of crushing hazard when grasping the platform guard rail.

SAFETY RULES

Observe and use the circle and square markings and the color-coded direction arrows on the platform controls and drive chassis for drive and steer functions.

Do not lower the boom unless the area below is clear of personnel and obstructions.



Limit travel speed according to the condition of ground surface, congestion, slope, location of personnel, and any other factors which may cause collision.

Do not operate a boom in the path of any crane unless the controls of the crane have been locked out and/or precautions have been taken to prevent any potential collision.

No stunt driving or horseplay while operating a machine.

Component Damage Hazards

Do not use any battery or charger greater than 12V to jump-start the engine.

Do not use the machine as a ground for welding.

Be sure the hydraulic shutoff valves (located by hydraulic tank) are open before starting the engine.

Explosion and Fire Hazards

Do not start the engine if you smell or detect liquid petroleum gas (LPG), gasoline, diesel fuel or other explosive substances.

Do not refuel the machine with the engine running.

Refuel the machine and charge the battery only in an open, well-ventilated area away from sparks, flames and lighted tobacco.

Do not operate the machine in hazardous locations or locations where potentially flammable or explosive gases or particles may be present.

SAFETY RULES

Damaged Machine Hazards

Do not use a damaged or malfunctioning machine.

Conduct a thorough pre-operation inspection of the machine and test all functions before each work shift. Immediately tag and remove from service a damaged or malfunctioning machine.

Be sure all maintenance has been performed as specified in this manual and the appropriate service manual.

Be sure all decals are in place and legible.

Be sure safety and operator's manuals are complete, legible and in the storage container located on the platform.

Bodily Injury Hazard

Do not operate the machine with a hydraulic oil or air leak. An air leak or hydraulic leak can penetrate and/or burn skin.

Always operate the machine in a well-ventilated area to avoid carbon monoxide poisoning.

Decal Legend

Genie product decals use symbols, color coding and signal words to identify the following:



Safety alert symbol—used to alert personnel to potential personal injury hazards. Obey all safety messages that follow this symbol to avoid possible injury or death.



Red—used to indicate the presence of an imminently hazardous situation which, if not avoided, will result in death or serious injury.



Orange—used to indicate the presence of a potentially hazardous situation which, if not avoided, could result in death or serious injury.



Yellow with safety alert symbol—used to indicate the presence of a potentially hazardous situation which, if not avoided, may cause minor or moderate injury.



Yellow without safety alert symbol—used to indicate the presence of a potentially hazardous situation which, if not avoided, may result in property damage.



Green—used to indicate operation or maintenance information.

Controls

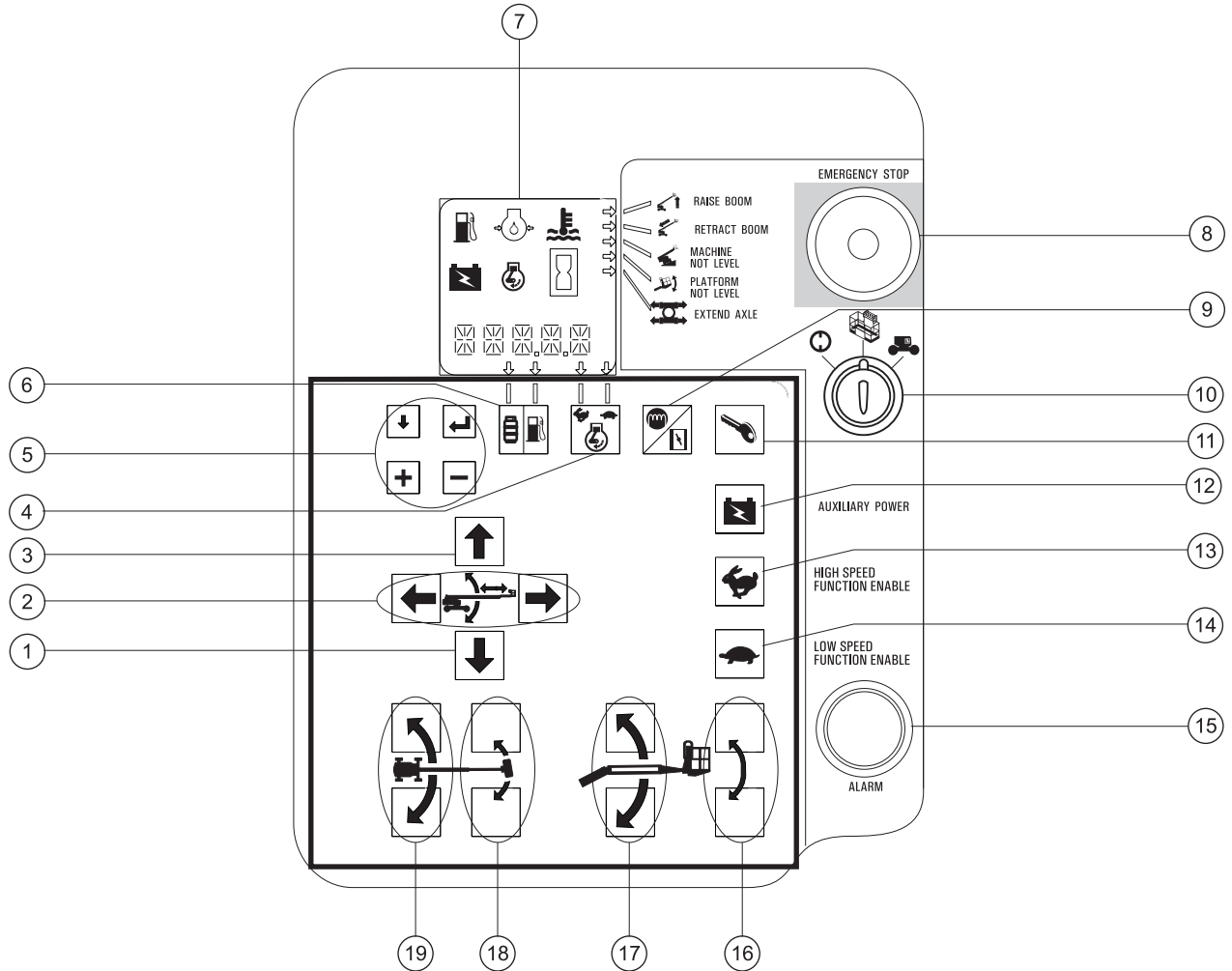

Ground Control Panel

- | | |
|--|---|
| 1 Boom down button | 11 Engine start button |
| 2 Boom extend/retract buttons | 12 Auxiliary power button |
| 3 Boom up button | 13 High speed function enable button |
| 4 Engine speed select button | 14 Low speed function enable button |
| 5 LCD screen control buttons | 15 Alarm |
| 6 Gasoline/LPG select button | 16 Platform level up/down buttons |
| 7 LCD readout screen | 17 S-125 models: Jib boom up/down buttons |
| 8 Emergency Stop button | 18 Platform rotate left/right buttons |
| 9 Gasoline/LPG models: Choke button
Deutz Diesel models: Glow plug button | 19 Turntable rotate left/right buttons |
| 10 Key switch for off/platform/ground selection | |

CONTROLS

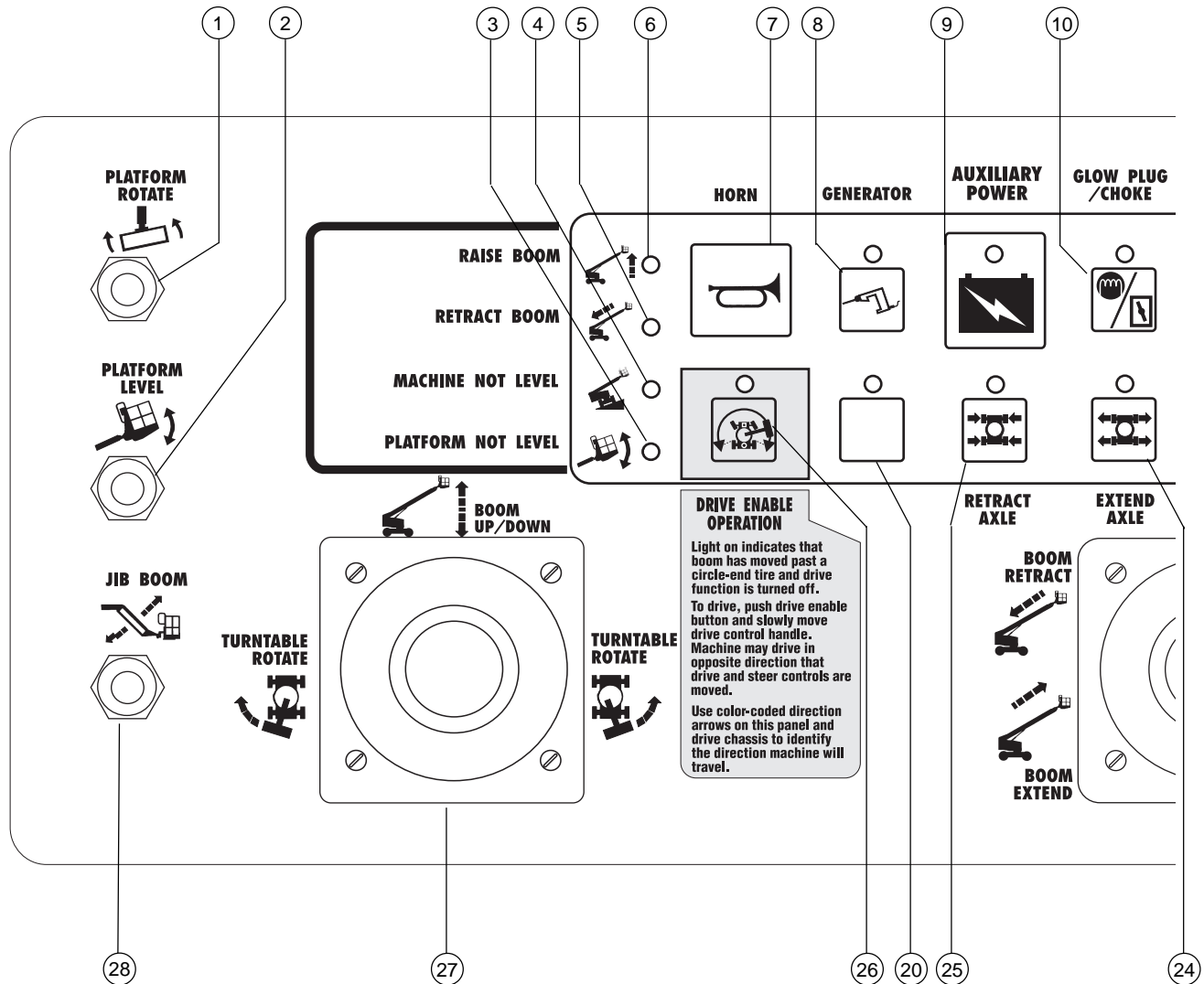

Platform Control Panel

- 1 Platform rotate switch
- 2 Platform level switch
- 3 Platform Not Level indicator light
- 4 Machine Not Level indicator light
- 5 Retract Boom indicator light
- 6 Raise Boom indicator light
- 7 Horn button
- 8 Generator button with indicator light (option)

- 9 Auxiliary power button with indicator light
- 10 Diesel models: Glow plug button with indicator light
Gasoline/LPG models: Choke button with indicator light
- 11 Engine start button with indicator light

- 12 Engine idle (rpm) select button with indicator lights:
 - Rabbit & Foot Switch: foot switch activated high idle
 - Turtle: low idle
 - Rabbit: high idle
- 13 Gasoline/LPG models: Gasoline/LPG select button with indicator lights
- 14 Fault indicator light
- 15 Low fuel indicator light
- 16 Check engine indicator light

CONTROLS

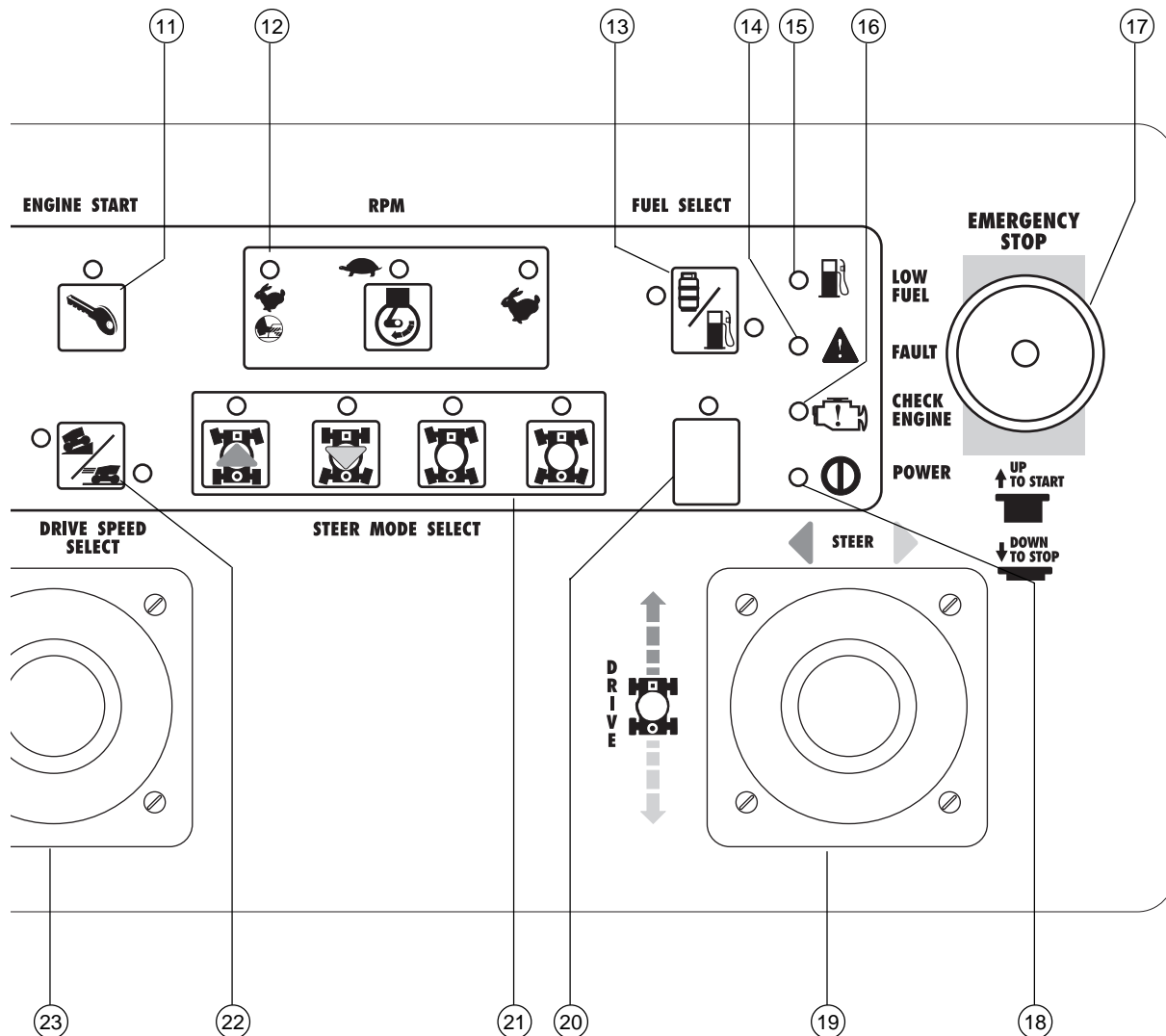

- 17 Emergency Stop button
- 18 Power indicator light
- 19 Dual axis proportional control handle for drive and steer functions
OR Proportional control handle for drive function and thumb rocker for steer function
- 20 Used for optional equipment
- 21 Steer mode select buttons with indicator lights

- 22 Drive select button with indicator lights:
Machine on incline symbol:
Low range operation for inclines
Machine on level surface symbol: High range operation for maximum drive speed
- 23 Single axis proportional control handle for boom extend/retract function

- 24 Extend axle button with indicator light
- 25 Retract axle button with indicator light
- 26 Drive enable button with indicator light
- 27 Dual axis proportional control handle for boom up/down and turntable rotate left/right functions
- 28 S-125 models: Jib boom up/down toggle switch

Pre-operation Inspection



Do Not Operate Unless:

- You learn and practice the principles of safe machine operation contained in this operator's manual.

1 Avoid hazardous situations.

2 Always perform a pre-operation inspection.

Know and understand the above principles before going on to the next section.

3 Always perform function tests prior to use.

4 Inspect the work place.

5 Only use the machine as it was intended.

Fundamentals

It is the responsibility of the operator to perform a Pre-operation Inspection and routine maintenance.

The Pre-operation Inspection is a visual inspection performed by the operator prior to each work shift. The inspection is designed to discover if anything is apparently wrong with a machine before the operator performs the function tests.

The Pre-operation Inspection also serves to determine if routine maintenance procedures are required. Only routine maintenance items specified in this manual may be performed by the operator.

Refer to the list on the next page and check each of the items and locations for modifications, damage or loose or missing parts.

A damaged or modified machine must never be used. If damage or any variation from factory delivered condition is discovered, the machine must be tagged and removed from service.

Repairs to the machine may only be made by a qualified service technician, according to the manufacturer's specifications. After repairs are completed, the operator must perform a pre-operation inspection again before going on to the function tests.

Scheduled maintenance inspections shall be performed by qualified service technicians, according to the manufacturer's specifications and the requirements listed in the responsibilities manual.

PRE-OPERATION INSPECTION

Pre-operation Inspection

- ❑ Be sure that the operator's, safety and responsibilities manuals are complete, legible and in the storage container located in the platform.
- ❑ Be sure that all decals are legible and in place. See Decals section.
- ❑ Check for engine oil leaks and proper oil level. Add oil if needed. See Maintenance section.
- ❑ Check for hydraulic oil leaks and proper oil level. Add oil if needed. See Maintenance section.
- ❑ Check for engine coolant leaks and proper level of coolant. Add coolant if needed. See Maintenance section.
- ❑ Check for battery fluid leaks and proper fluid level. Add distilled water if needed. See Maintenance section.

Check the following components or areas for damage and improperly installed, loose or missing parts:

- ❑ Electrical components, wiring and electrical cables
- ❑ Hydraulic hoses, fittings, cylinders and manifolds
- ❑ Fuel and hydraulic tanks
- ❑ Drive and turntable motors and drive hubs
- ❑ Boom and axle wear pads
- ❑ Tires and wheels
- ❑ Engine and related components
- ❑ Limit switches and horn
- ❑ Alarms and beacons (if equipped)
- ❑ Nuts, bolts and other fasteners
- ❑ Platform entry mid-rail or gate

Check entire machine for:

- ❑ Crack in welds or structural components
- ❑ Dents or damage to machine
- ❑ Be sure that all structural and other critical components are present and all associated fasteners and pins are in place and properly tightened.
- ❑ After you complete your inspection, be sure that all compartment covers are in place and latched.

Maintenance



Observe and Obey:

- ☑ Only routine maintenance items specified in this manual shall be performed by the operator.
- ☑ Scheduled maintenance inspections shall be completed by qualified service technicians, according to the manufacturer's specifications and the requirements specified in the responsibilities manual.

Maintenance Symbols Legend

NOTICE The following symbols have been used in this manual to help communicate the intent of the instructions. When one or more of the symbols appear at the beginning of a maintenance procedure, it conveys the meaning below.



Indicates that tools will be required to perform this procedure.



Indicates that new parts will be required to perform this procedure.



Indicates that a cold engine is required before performing this procedure.

Check the Engine Oil Level



Maintaining the proper engine oil level is essential to good engine performance and service life. Operating the machine with an improper oil level can damage engine components.

NOTICE Check the oil level with the engine off.

- 1 Check the engine oil dipstick. Add oil as needed.

Cummins models:

- ⊙ Result: The oil level should be within the "L" and "H" marks on the dipstick.

Deutz models:

- ⊙ Result: The oil level should be within the two marks on the dipstick.

Perkins models:

- ⊙ Result: The oil level should be within the two notches on the dipstick.

Cummins B3.9L Engine	11.5 quarts
Oil capacity (including filter)	10.9 liters

Cummins B3.9L Engine Oil viscosity requirements

below 68°F / 20°C	5W-30
-10° to 68°F / -23° to 20°C	10W-30
above 15°F / -9°C	15W-40

Use oils meeting API classification CE (labeled CE/SG).

Deutz F4L 913 Engine	14 quarts
Oil capacity (including filter)	13.5 liters

Deutz F4L 913 Engine Oil viscosity requirements

below 60°F / 15.5°C (synthetic)	5W-30
-10°F to 90°F / -23°C to 32°C	10W-40
above -4°F / -34°C	15W-40

Engine oil should have properties of API classification CC/SE or CC/SF grades.

Perkins 1004-42 Engine Oil capacity (including filter)	8.9 quarts 8.4 liters
---	--------------------------

Perkins 1004-42 Engine Oil viscosity requirements

below 32°F / 0°C	0W
-13°F to 68°F / -25°C to 20°C	5W-20
10°F to 104°F / -12°C to 40°C	10W-30
14°F to 122°F / -10°C to 50°C	15W-40
above 23°F / -5°C	20W-50

Engine oil should have properties of API classification CF4 grade.

Check the Hydraulic Oil Level



Maintaining the hydraulic oil at the proper level is essential to machine operation. Improper hydraulic oil levels can damage hydraulic components. Daily checks allow the inspector to identify changes in oil level that might indicate the presence of hydraulic system problems.

- 1 Be sure that the boom is in the stowed position, then visually inspect the sight gauge located on the side of the hydraulic oil tank.
- ⦿ Result: The hydraulic oil level should be within the top 2 inches (5 cm) of the sight gauge.

Hydraulic oil specifications

Hydraulic oil type	Dexron equivalent	
Tank capacity	55 gallons	208 liters
Hydraulic system (including tank)	65 gallons	246 liters

Check the Batteries



Proper battery condition is essential to good engine performance and operational safety. Improper fluid levels or damaged cables and connections can result in engine component damage and hazardous conditions.

⚠ WARNING Electrocutation hazard. Contact with hot or live circuits may result in death or serious injury. Remove all rings, watches and other jewelry.

⚠ WARNING Bodily injury hazard. Batteries contain acid. Avoid spilling or contacting battery acid. Neutralize battery acid spills with baking soda and water.

- 1 Put on protective clothing and eye wear.
- 2 Be sure that the battery cable connections are free of corrosion.
- 3 Be sure that the battery hold downs and cable connections are tight.
- 4 Remove the battery vent caps.
- 5 Check the battery acid level. If needed, replenish with distilled water to the bottom of the battery fill tube. Do not overfill.
- 6 Install the vent caps.

NOTICE Adding terminal protectors and a corrosion preventative sealant will help eliminate corrosion on the battery terminals and cables.

MAINTENANCE

Check the Engine Coolant Level - Liquid Cooled Models



Maintaining the engine coolant at the proper level is essential to engine service life. Improper coolant level will affect the engine's cooling capability and damage engine components. Daily checks will allow the inspector to identify changes in coolant level that might indicate cooling system problems.

- 1 Check the fluid level in the coolant recovery tank. Add fluid as needed.

⊙ **Result:** The fluid level should be in the NORMAL range.

AWARNING Bodily injury hazard. Fluids in the radiator are under pressure and extremely hot. Use caution when removing cap and adding fluids.

Scheduled Maintenance

The scheduled maintenance items must be completed by a person trained and qualified to perform maintenance on this machine according to the procedures found in the service manual for this machine.

Inspections and maintenance described below require the qualified entity to record and retain records of all inspections and maintenance items for four years.

Machines that have been out of service for more than three months must receive the quarterly inspection before placing the machine back into service.

The Schedule

There are five types of maintenance inspections that must be performed according to a schedule—daily, quarterly, six months, annual, two year. To account for repeated procedures, the *Scheduled Maintenance Procedures Section and the Maintenance Inspection Report* have been divided into five subsections—A, B, C, D and E. Use the following chart to determine which group(s) of procedures are required to perform a scheduled inspection.

Inspection	Table or Checklist
Daily or every 8 hours	A
Quarterly or every 250 hours	A + B
Six months or every 500 hours	A + B + C
Annual or every 1000 hours	A + B + C + D
Two year or every 2000 hours	A + B + C + D + E

Maintenance Inspection Report

The maintenance inspection report contains checklists for each type of scheduled inspection.

Make copies of the *Maintenance Inspection Report* to use for each inspection. Store completed forms for three years.

Function Tests



Do Not Operate Unless:

- ☑ You learn and practice the principles of safe machine operation contained in this operator's manual.

- 1 Avoid hazardous situations.
- 2 Always perform a pre-operation inspection.

3 Always perform function tests prior to use.

Know and understand the above principles before going on to the next section.

- 4 Inspect the work place.
- 5 Only use the machine as it was intended.

Fundamentals

The Function Tests are designed to discover any malfunctions before the machine is put into service. The operator must follow the step-by-step instructions to test all machine functions.

A malfunctioning machine must never be used. If malfunctions are discovered, the machine must be tagged and removed from service. Repairs to the machine may only be made by a qualified service technician, according to the manufacturer's specifications.

After repairs are completed, the operator must perform a pre-operation inspection and function tests again before putting the machine into service.

- 1 Select a test area that is firm, level and free of obstruction.

At the Ground Controls

- 2 Turn the key switch to ground control.
- 3 Pull out the red Emergency Stop button to the ON position.
- ☉ Result: The LCD screen will come on and display no error messages. The beacon (if equipped) should flash.

Note: In cold climates, the LCD readout screen will need to warm up before the display appears.

- 4 Start the engine (see Operating Instructions section).

Test Emergency Stop

- 5 Push in the red Emergency Stop button to the OFF position.
- ☉ Result: The engine should turn off and no functions should operate.
- 6 Pull out the red Emergency Stop button to the ON position and restart the engine.

Test the Extendable Axles

Note: Start this test with the axles retracted.

- 7 At the ground controls, push and hold a function enable/speed select button and push the boom up button.
- ☉ Result: The boom should raise to 10° above horizontal and then stop. The boom should not raise above the limit switch unless both axles are extended.
- 8 Push and hold a function enable/speed select button and push the boom down button.
- ☉ Result: The boom should lower and return to the stowed position.

FUNCTION TESTS

- 9 Push and hold a function enable/speed select button and press the boom extend button.
- ⦿ Result: The boom will extend approximately 3 feet (1 m) and then stop. The boom should not extend farther unless both axles are extended.
- 10 Push and hold a function enable/speed select button and push the boom retract button.
- ⦿ Result: The boom should retract.
- 11 At the platform controls, move the drive control handle in the forward direction and push the extend axle button.
- ⦿ Result: The machine should drive and the axles should extend. The indicator light will flash while the axles are moving and stay on when the axles are fully extended.
- Note: The extend axle function will only work while the machine is moving.
- 12 Return to the ground controls. At the ground controls, push and hold a function enable/speed select button and push the boom up button and the boom down button.
- ⦿ Result: The boom should raise and lower normally.
- 13 At the ground controls, push and hold a function enable/speed select button and push the boom extend button and the boom retract button.
- ⦿ Result: The boom should extend and retract normally.

Test the Machine Functions

- 14 Do not press and hold a function enable/speed select button. Attempt to activate each boom and platform function button.
- ⦿ Result: No boom and platform functions should operate.
- 15 Press and hold a function enable /speed select button and activate each boom and platform function button.
- ⦿ Result: All boom and platform functions should operate through a full cycle. Descent alarm (if equipped) should sound while boom is lowering.

Test Auxiliary Controls

- 16 Turn the key switch to ground control and shut the engine off.
- 17 Pull out the red Emergency Stop button to the ON position.
- 18 Simultaneously push and hold the auxiliary power button and push each boom function button or activate each boom function toggle switch.

Note: To conserve battery power, test each function through a partial cycle.

- ⦿ Result: All boom functions should operate.

FUNCTION TESTS

Test the Tilt Sensor

19 Push one of the LCD screen buttons until TURNTABLE LEVEL SENSOR X-DIRECTION appears.



⦿ Result: The LCD screen should display the angle in degrees.

20 Push one of the LCD screen buttons until TURNTABLE LEVEL SENSOR Y-DIRECTION appears.

⦿ Result: The LCD screen should display the angle in degrees.

21 Push one of the LCD screen buttons until PLATFORM LEVEL SENSOR DEGREES appears.

⦿ Result: The LCD screen should display the angle in degrees.

Test the Operating Envelope

22 Simultaneously push the LCD screen buttons shown to activate status mode.



23 Push one of the LCD screen buttons shown until BOOM ANGLE is displayed.



24 Raise the boom and observe the LCD screen.

⦿ Result: The LCD screen should display:
 < 10
 >= 10
 >= 50
 > 65

25 Push one of the LCD screen buttons shown until BOOM LENGTH is displayed.

26 Extend the boom and observe the LCD screen.

⦿ Result: The LCD screen should display:
 at 0
 > 0
 > 80
 = 100
 > 100

27 Retract the boom.

At the Platform Controls

Test Emergency Stop

28 Turn the key switch to platform control.

29 Push in the platform red Emergency Stop button to the OFF position.

⦿ Result: The engine should turn off and no functions should operate.

30 Pull out the red Emergency Stop button and restart the engine.

Test the Hydraulic Oil Return Filter

31 Press the engine idle speed select button until the indicator light next to high idle (rabbit symbol) is on.

32 Locate and check the hydraulic filter condition indicator.

⦿ Result: The filter should be operating with the plunger in the green area.

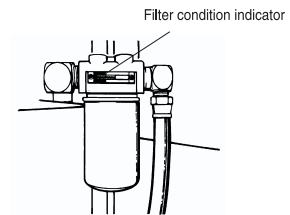

33 Press the engine idle speed select button until the indicator light next to foot switch activated high idle (rabbit and foot switch symbol) is on.

FUNCTION TESTS

Test the Horn

34 Push the horn button.

- ⦿ Result: The horn should sound.

Test the Tilt Sensor Alarm

35 Push a button, such as the engine RPM button or the fuel select button.

- ⦿ Result: The alarm should sound at the platform controls.

Test the Foot Switch

36 Push in the platform red Emergency Stop button to the OFF position.

37 Pull out the red Emergency Stop button to the ON position but do not start the engine.

38 Press down the foot switch and attempt to start the engine by pushing the engine start button.

- ⦿ Result: The engine should **not** start.
- 39 Do not press down the foot switch and restart the engine.
- 40 Do not press down the foot switch and test each machine function.
- ⦿ Result: No machine functions should operate.

Test Machine Functions

41 Press down the foot switch.

42 Activate each machine function control handle, toggle switch or button.

- ⦿ Result: All functions should operate through a full cycle.

Test the Steering

43 Push the steer mode select button for square-end (blue arrow) steer.

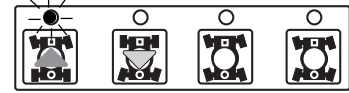

44 Press down the foot switch.

45 Slowly move the drive/steer control handle in the direction indicated by the blue triangle on the control panel OR press the thumb rocker switch in the direction indicated by the blue triangle.

- ⦿ Result: The square-end wheels should turn in the direction that the blue triangles point on the drive chassis.

46 Push the steer mode select button for circle-end (yellow arrow) steer.

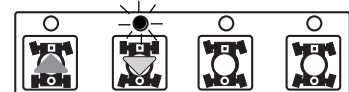

47 Press down the foot switch.

48 Slowly move the drive/steer control handle in the direction indicated by the yellow triangle on the control panel OR press the thumb rocker switch in the direction indicated by the yellow triangle.

- ⦿ Result: The circle-end wheels should turn in the direction that the yellow triangles point on the drive chassis.

49 Push the steer mode select button for crab steer.

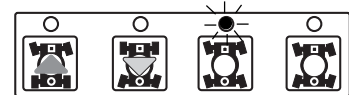

50 Press down the foot switch.

51 Slowly move the drive/steer control handle in the direction indicated by the blue triangle on the control panel OR press the thumb rocker switch in the direction indicated by the blue triangle..

- ⦿ Result: All wheels should turn in the direction that the blue triangles point on the drive chassis.

FUNCTION TESTS

52 Push the steer mode select button for coordinated steer.

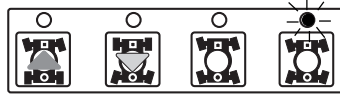

53 Press down the foot switch.

54 Slowly move the drive/steer control handle in the direction indicated by the blue triangle on the control panel OR press the thumb rocker switch in the direction indicated by the blue triangle..

- Result: The square-end wheels should turn in the direction that the blue triangles point on the drive chassis. The circle-end wheels should turn in the direction that the yellow triangles point on the drive chassis.

Test Drive and Braking

55 Press down the foot switch.

56 Slowly move the drive/steer control handle in the direction indicated by the blue arrow on the control panel until the machine begins to move, then return the handle to the center position.

- Result: The machine should move in the direction that the blue arrow points on the drive chassis, then come to an abrupt stop.

57 Slowly move the drive/steer control handle in the direction indicated by the yellow arrow on the control panel until the machine begins to move, then return the handle to the center position.

- Result: The machine should move in the direction that the yellow arrow points on the drive chassis, then come to an abrupt stop.

Note: The brakes must be able to hold the machine on any slope it is able to climb.

Test the Drive Enable System

58 Press down the foot switch and lower the boom to the stowed position.

59 Rotate the turntable until the boom moves past one of the circle-end tires.

- Result: The drive enable indicator light should come on while the boom is anywhere in the range shown.



60 Move the drive/steer control handle off center.

- Result: No drive function should operate.

61 Push the drive enable button and slowly move the drive/steer control handle off center.

- Result: The drive function should operate.

Note: When the drive enable system is in use, the machine may drive in the opposite direction that the drive and steer control handle is moved.

Use the color-coded direction arrows on the platform controls and the drive chassis to identify the direction of travel.

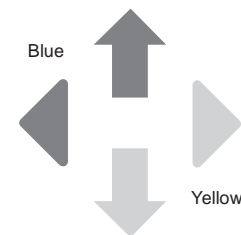

If the drive/steer control handle is not moved within two seconds of pushing the drive enable button, the drive function will not operate.

FUNCTION TESTS

Test Limited Drive Speed

62 Press down the foot switch.

63 Raise the boom to 10° above horizontal.

64 Slowly move the drive control handle to the full drive position.

- ⦿ Result: The maximum achievable drive speed with the boom raised should not exceed 1 foot per second (0.3 meters per second).

Note: The machine will travel 40 feet in 40 seconds (12.2 meters in 40 seconds).

65 Lower the boom to the stowed position.

66 Extend the boom 4 feet (1.2 m).

67 Slowly move the drive control handle to the full drive position.

- ⦿ Result: The maximum achievable drive speed with the boom extended should not exceed 1 foot per second (0.3 meters per second).

Note: The machine will travel 40 feet in 40 seconds (12.2 meters in 40 seconds).

If the drive speed with the boom raised or extended exceeds 1 foot per second (0.3 meters per second), immediately tag and remove the machine from service.

68 Raise the boom to horizontal. Extend the boom as far as it will go.

69 Slowly move the drive control handle to the full drive position.

- ⦿ Result: The maximum achievable drive speed with the boom fully extended should not exceed 0.6 feet per second (0.2 meters per second).

Note: The machine will travel 40 feet in 70 seconds (12.2 meters in 70 seconds).

Test Auxiliary Controls

70 Shut off the engine.

71 Pull out the red Emergency Stop button to the ON position.

72 Press down the foot switch.

73 Simultaneously press and hold the auxiliary power button and activate each function control handle, toggle switch or button.

Note: To conserve battery power, test each function through a partial cycle.

- ⦿ Result: All boom and steer functions should operate. Machines equipped with the auxiliary power drive option: The drive function should operate.

Work Place Inspection



Do Not Operate Unless:

- You learn and practice the principles of safe machine operation contained in this operator's manual.

- 1 Avoid hazardous situations.
- 2 Always perform a pre-operation inspection.
- 3 Always perform function tests prior to use.

4 Inspect the work place.

Know and understand the above principles before going on to the next section.

- 5 Only use the machine as it was intended.

Work Place Inspection

Be aware of and avoid the following hazardous situations:

- drop-offs or holes
- bumps, floor obstructions or debris
- overhead obstructions and high voltage conductors
- hazardous locations
- inadequate surface support to withstand all load forces imposed by the machine
- wind and weather conditions
- the presence of unauthorized personnel
- other possible unsafe conditions

Fundamentals

The Work Place Inspection helps the operator determine if the work place is suitable for safe machine operation. It should be performed by the operator prior to moving the machine to the work place.

It is the operator's responsibility to read and remember the work place hazards, then watch for and avoid them while moving, setting up and operating the machine.

Operating Instructions



Do Not Operate Unless:

- ☑ You learn and practice the principles of safe machine operation contained in this operator's manual.

- 1 Avoid hazardous situations.
- 2 Always perform a pre-operation inspection.
- 3 Always perform function tests prior to use.
- 4 Inspect the work place.
- 5 Only use the machine as it was intended.**

Fundamentals

The Operating Instructions section provides instructions for each aspect of machine operation. It is the operator's responsibility to follow all the safety rules and instructions in the operator's, safety and responsibilities manuals.

Using the machine for anything other than lifting personnel and tools to an aerial work site is unsafe and dangerous.

Only trained and authorized personnel should be permitted to operate a machine. If more than one operator is expected to use a machine at different times in the same work shift, they must all be qualified operators and are all expected to follow all safety rules and instructions in the operator's, safety and responsibilities manuals. That means every new operator should perform a pre-operation inspection, function tests, and a work place inspection before using the machine.

Starting the Engine

- 1 At the ground controls, turn the key switch to the desired position.
- 2 Be sure both the ground and platform control red Emergency Stop buttons are pulled out to the ON position.
- 3 Gasoline/LPG models: Choose fuel by pressing the fuel select button.
- 4 Press the engine start button. If the engine fails to start or dies, the restart delay will disable the start button for 3 seconds.



If the engine fails to start after 15 seconds of cranking, determine the cause and repair any malfunction. Wait 60 seconds before trying to start again.

All models: In extreme cold conditions, 20°F (-6°C) and below, warm the engine for 5 minutes to prevent hydraulic system damage.

Gasoline/LPG models: In extreme cold conditions, 20°F (-6°C) and below, the machine should be started on gasoline, then switched to LPG.

Emergency Stop

Push in either the ground or platform red Emergency Stop button to the OFF position to stop all functions and turn the engine off.

Repair any function that operates when the Emergency Stop button is pushed in to the OFF position.

Selecting and operating the ground controls will override the platform Emergency Stop button.

OPERATING INSTRUCTIONS

Auxiliary Controls

Use auxiliary power if the primary power source (engine) fails.

- 1 Turn the key switch to ground or platform control.
- 2 Pull out the red Emergency Stop button to the ON position.
- 3 Press down the foot switch when operating the auxiliary controls from the platform.
- 4 Simultaneously hold the auxiliary power button and activate the desired function.

Machines equipped with the auxiliary power drive option: The drive function will operate.

Operation from Ground

- 1 Turn the key switch to ground control.
- 2 Pull out the red Emergency Stop button to the ON position.
- 3 Gasoline/LPG models: Choose fuel by pressing the fuel select button.
- 4 Start the engine.

To Position Platform

- 1 Push and hold a function enable/speed select button.
- 2 Push the appropriate function button according to the markings on the control panel.



Drive and steer functions are not available from the ground controls.

Operation from Platform

- 1 Turn the key switch to platform control.
- 2 Pull out both ground and platform red Emergency Stop buttons to the ON position.
- 3 Gasoline/LPG models: Choose fuel by pressing the fuel select button.
- 4 Start the engine. Do not press down the foot switch when starting the engine.

To Position Platform

- 1 Press down the foot switch.
- 2 Slowly move the appropriate function control handle or toggle switch or press the appropriate button according to the markings on the control panel.

To Steer

- 1 Press down the foot switch.
- 2 Select the steer mode by pressing a steer mode button. The indicator light next to the current steer mode will be on.

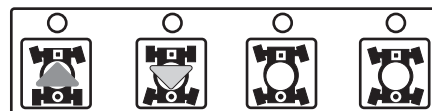

- 3 Slowly move the drive/steer control handle in the blue or yellow triangle direction OR press the thumb roller switch located on top of the drive control handle.



Use the color-coded direction arrows on the platform controls and the drive chassis to identify the direction the wheels will turn.

OPERATING INSTRUCTIONS

To Drive

- 1 Press down the foot switch.
 - 2 Increase speed: Slowly move the drive/steer control in the blue or yellow arrow direction.
- Decrease speed: Slowly move the drive/steer control handle toward center.
- Stop: Return the drive/steer control handle to center or release the foot switch.



Use the color-coded direction arrows on the platform controls and the drive chassis to identify the direction the machine will travel.

Machine travel speed is restricted when the boom is raised or extended.

Drive Enable

Light on indicates that the boom has moved past either circle-end wheel and drive function is turned off.

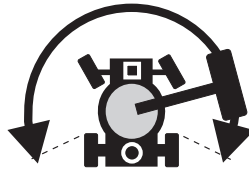

To drive, push the drive enable button and slowly move the drive/steer control handle off center.

If the drive/steer control handle is not moved within two seconds of pushing the drive enable button, the drive function will not operate. Release and push the drive enable button again.

Be aware that the machine may move in the opposite direction that the drive and steer controls are moved.

Always use the color-coded direction arrows on the platform controls and the drive chassis to identify the direction the machine will travel.

Non-regulated Generator (if equipped)

To operate the generator, press the generator button. The indicator light will come on and the engine rpm will automatically be in turtle symbol mode.

The engine will continue to run the drive functions and the platform functions will operate.

If the rabbit symbol or the rabbit and footswitch symbol are selected, the generator will shut off and the indicator light will go off.

Plug power tools into the power to platform GFCI outlet.

To turn off the generator, push the generator button. The indicator light will turn off.

Regulated Generator (if equipped)

To operate the generator, press the generator button. The indicator light will come on and the engine will continue to run.

Plug power tools into the power to platform GFCI outlet.

To turn off the generator, push the generator button. The indicator light will turn off.

Engine Idle Select (rpm)

Select the engine idle (rpm) by pressing the select button. The indicator light next to the current setting will be on.

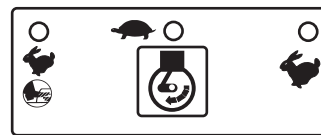

- Rabbit and foot switch symbol: foot switch activated high idle
- Turtle symbol: low idle
- Rabbit symbol: high idle

OPERATING INSTRUCTIONS

Check Engine Light

Light on and engine stopped: Tag the machine and remove from service.

Light on and engine still running: Contact service personnel within 24 hours.

Operating Envelope Indicator Lights

The operating envelope indicator lights will come on to notify the operator that a function has been interrupted (in some cases) and/or an action is required by the operator.

Raise Boom indicator light flashing: To continue extending the boom, raise the boom until the indicator light is off.

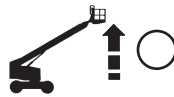

Retract Boom indicator light flashing: To continue lowering the boom, retract the boom until the indicator light is off.



Machine Not Level indicator light flashing: The tilt alarm will be sounding when this light is flashing. Move the machine to a firm level surface.

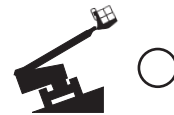

Platform Not Level indicator light flashing: The tilt alarm will be sounding when this light is flashing. The Platform Level toggle switch will only work in the direction that will level the platform. Level the platform until the indicator light is off.



Stopping the Engine

Push in the red Emergency Stop button and turn the key switch to the OFF position.

After Each Use

- 1 Select a safe parking location—firm level surface, clear of obstruction and traffic.
- 2 Retract and lower the boom to the stowed position.
- 3 Rotate the turntable so that the boom is between the circle-end wheels.
- 4 Turn the key switch to the OFF position and remove the key to secure from unauthorized use.
- 5 Chock the wheels.

Transport Instructions



Transport Instructions Observe and Obey:

- ☑ Transport vehicle must be parked on a level surface.
- ☑ Transport vehicle must be secured to prevent rolling while machine is being loaded.
- ☑ Be sure vehicle capacity, loading surfaces and straps or lines are sufficient to withstand machine weight (see Specifications section).
- ☑ Be sure the turntable is secured with the turntable rotation lock before transporting. Be sure to unlock the turntable for operation.

Securing to Truck or Trailer for Transit

Always use the turntable rotation lock pin each time the machine is transported.

Always chock machine wheels in preparation for transport.

Use tie points on drive chassis for anchoring down to transport surface.

Use chains or straps of ample load capacity.

Turn key switch to the OFF position and remove key before transporting.

Inspect entire machine for loose or unsecured items.

Free-wheel Configuration for Winching

Chock wheels to prevent machine from rolling.

4WD models: Release wheel brakes by turning over all four torque hub disconnect caps (see below).

Be sure winch line is properly secured to drive chassis tie points and path is clear of all obstructions.

Reverse procedures described to re-engage brakes.

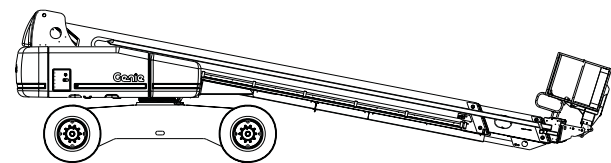
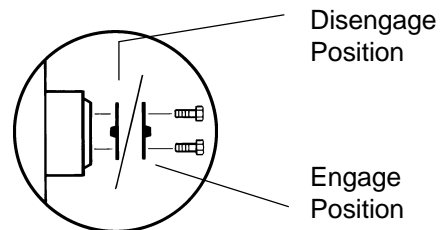

Transport configuration: S-120

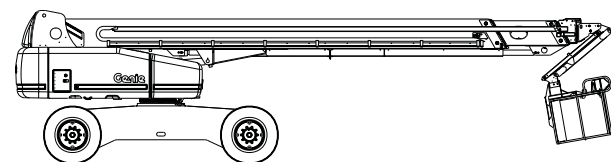

Transport configuration: S-125

Decals

Decal Inspection

Use the pictures on the next page to verify that all decals are legible and in place.

Below is a numerical list with quantities and descriptions.

Part No.	Description	Quantity	Part No.	Description	Quantity
25994	Caution, Component Damage Hazard	1	65182	Platform Control Panel	1
27204	Arrow, Blue	1	65264	Cosmetic, Genie S-125	1
27205	Arrow, Yellow	1	65265	Cosmetic, S-125	1
27206	Triangle, Blue	2	65266	Cosmetic, 4x4	1
27207	Triangle, Yellow	2	65267	Cosmetic, Genie S-120	1
27564	Danger - Electrocutation Hazard	4	65268	Cosmetic, S-120	1
28157	Label - Dexron	1	65269	Notice, Operating Instructions	2
28159	Label, Diesel	1	65272	Serial Plate	1
28161	Warning, Crush Hand	4	65273	Notice, Tire Specifications	4
28163	Notice, Max. Side Force, 150 lbs, ANSI & CSA	1	65274	Notice, Engine Specifications, Deutz	1
28164	Notice, Hazardous Materials	1	65275	Notice, Engine Specifications, Cummins	1
28165	Notice, Footswitch	1	65276	Notice, Engine Specifications, Perkins	1
28171	Label, No Smoking	1	65278	Caution, No Step	4
28174	Label, Power to Platform, 230V	2	65428	Danger, Tip-over Hazard, Tires	4
28175	Caution, Compartment Access	1	72051	Label, 20 amp Circuit Breaker	1
28176	Notice, Missing Manuals	1	72052	Label, 40 amp Circuit Breaker	1
28177	Warning, Collision Hazard	2	72053	Label, 30 amp Circuit Breaker	1
28181	Warning, No Step or Ride	1	72087	Warning, Weld Line to Platform	2
28235	Label, Power to Platform, 115V	2	72119	Label, Range of Motion Chart	1
28236	Warning, Failure To Read . . .	1	72130	Warning, Bodily Injury Hazard	2
30080	Notice, Maximum Capacity, 500 lbs, S-125	1	72131	Label, Cylinder Cover	2
32700	Danger, General Safety	2	72168	Notice, Starter Battery	1
33952	Danger, Tip-over Hazard	1	72169	Notice, Controls Battery	1
40434	Label, Lanyard Anchorage Point	2	72866	Warning, Explosion Hazard	2
43594	Notice, Maximum Capacity, 750 lbs, S-120	1			
44986	Notice, Max. Manual Force, 90 lbs, CE	1			
61227	Ground Control Panel	1			

 Shading indicates decal is hidden from view, i.e. under covers

DECALS

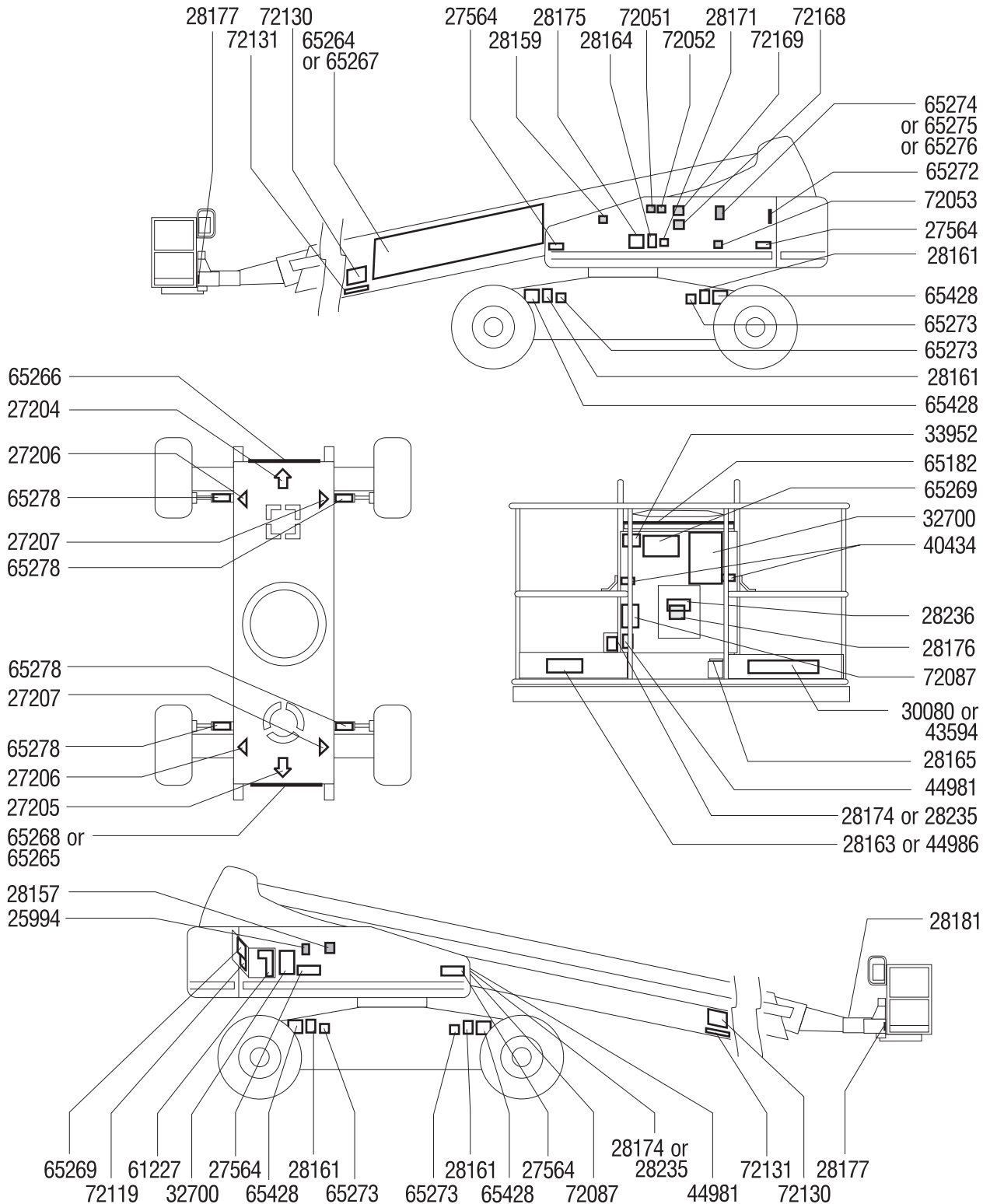

Specifications

S-120		
Height, working maximum	126 ft	38.4 m
Height, platform maximum	120 ft	36.6 m
Height, stowed maximum	10 ft 1 in	3.1 m
Horizontal reach maximum	75 ft	22.9 m
Width, axles retracted	8 ft 6 in	2.6 m
Width, axles extended	11 ft 6 in	3.5 m
Length, stowed	39 ft 11 in	12.2 m
Maximum load capacity	750 lb	340 kg
Wheelbase	12 ft	3.7 m
Turning radius, outside, axles retracted	24 ft 4 in	7.4 m
Turning radius, inside, axles retracted	16 ft 4 in	4.9 m
Turning radius, outside, axles extended	20 ft 8 in	6.3 m
Turning radius, inside, axles extended	10 ft 1 in	3.1 m
Turntable rotation (degrees)	360 continuous	
Turntable tailswing, axles retracted	66 in	168 cm
Turntable tailswing, axles extended	48 in	122 cm
Power source (choice)	Perkins Diesel 1004-42 Deutz Diesel F4L913 Cummins Diesel 4B3.9	
Drive speed, stowed	3.0 mph 40 ft/9.1 sec	4.4 km/h 12.2 m/9.1 sec
Drive speed, raised or extended	0.7 mph 40 ft/40 sec	1.1 km/h 12.2 m/40 sec
Drive speed, fully extended	0.4 mph 40 ft/70 sec	0.6 km/h 12.2 m/70 sec

S-120		
Controls	12V DC proportional	
Platform dimensions, length x width	96 x 36 in 2.4 m x 91 cm	
Platform leveling	self-leveling	
Platform rotation	160°	
AC outlet in platform	standard	
Hydraulic pressure (maximum) (drive functions)	4250 psi	293 bar
Tire size	18 x 22.5, 18 pr FF	
Gradeability, stowed	40 %	
Ground clearance	15 ³ / ₄ in	40 cm
Hydraulic tank capacity	55 gallons	208 liters
Fuel tank capacity	40 gallons	151 liters
Weight	44,340 lbs	20,112 kg
Airborne noise emissions	80 dB	
Maximum sound level at normal operating workstations (A-weighted)		

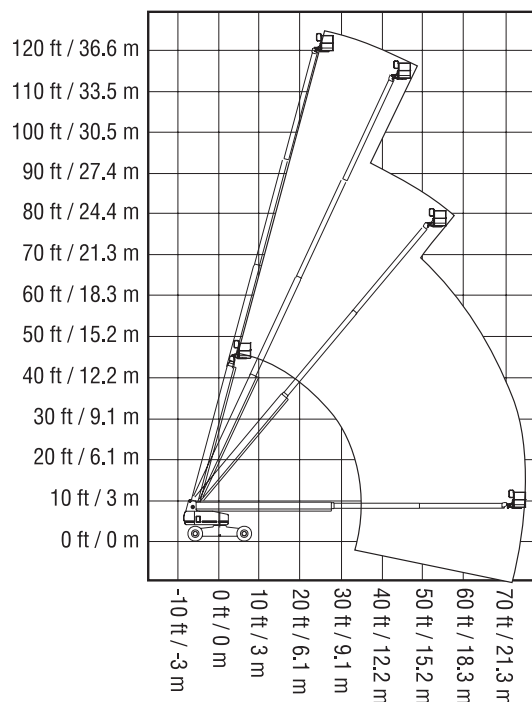

Continuous improvement of our products is a Genie policy. Product specifications are subject to change without notice or obligation.

SPECIFICATIONS

S-125		
Height, working maximum	131 ft	39.9 m
Height, platform maximum	125 ft	38.1 m
Height, stowed maximum	10 ft 1 in	3.1 m
Horizontal reach maximum	80 ft	24.4 m
Width, axles retracted	8 ft 6 in	2.6 m
Width, axles extended	11 ft 6 in	3.5 m
Length, stowed	39 ft 11 in	12.2 m
Maximum load capacity	500 lb	227 kg
Wheelbase	12 ft	3.7 m
Turning radius, outside, axles retracted	24 ft 4 in	7.4 m
Turning radius, inside, axles retracted	16 ft 4 in	4.9 m
Turning radius, outside, axles extended	20 ft 8 in	6.3 m
Turning radius, inside, axles extended	10 ft 1 in	3.1 m
Turntable rotation (degrees)	360 continuous	
Turntable tailswing, axles retracted	66 in	168 cm
Turntable tailswing, axles extended	48 in	122 cm
Power source (choice)	Perkins Diesel 1004-42 Deutz Diesel F4L913 Cummins Diesel 4B3.9	
Drive speed, stowed	3.0 mph 40 ft/9.1 sec	4.4 km/h 12.2 m/9.1 sec
Drive speed, raised or extended	0.7 mph 40 ft/40 sec	1.1 km/h 12.2 m/40 sec
Drive speed, fully extended	0.4 mph 40 ft/70 sec	0.6 km/h 12.2 m/70 sec

S-125		
Controls	12V DC proportional	
Platform dimensions, length x width	96 x 36 in 2.4 m x 91 cm	
Platform leveling	self-leveling	
Platform rotation	160°	
AC outlet in platform	standard	
Hydraulic pressure (maximum) (drive functions)	4250 psi	293 bar
Tire size	18 x 22.5, 18 pr FF	
Gradeability, stowed	40 %	
Ground clearance	15 ³ / ₄ in	40 cm
Hydraulic tank capacity	55 gallons	208 liters
Fuel tank capacity	40 gallons	151 liters
Weight	44,640 lbs	20,248 kg
Airborne noise emissions	80 dB	
Maximum sound level at normal operating workstations (A-weighted)		

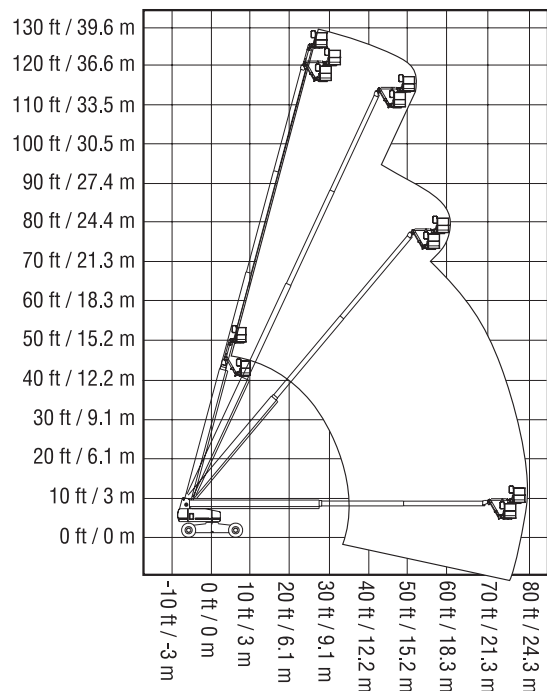

Continuous improvement of our products is a Genie policy. Product specifications are subject to change without notice or obligation.

California Proposition 65

WARNING

The exhaust from this product contains chemicals known to the State of California to cause cancer, birth defects or other reproductive harm.

Genie Holland

Phone +31 70 51 78836
Fax +31 70 51 13993

Genie Scandinavia

Phone +46 31 3409612
Fax +46 31 3409613

Genie France

Phone +33 (0)2 37 26 09 99
Fax +33 (0)2 37 26 09 98

Genie Ibérica

Phone +34 93 579 5042
Fax +34 93 579 5059

Genie Germany

Phone +49 (0)4202 88520
Fax +49 (0)4202 8852-20

Genie U.K.

Phone +44 (0)1476 584333
Fax +44 (0)1476 584334

Genie Mexico City

Phone +52 5 653 03 84
Fax +52 5 664 40 16

Genie North America

Phone 425.881.1800
Toll Free USA and Canada
800.536.1800
Fax 425.883.3475

Genie Australia Pty Ltd.

Phone +61 7 3375 1660
Fax +61 7 3375 1002

Genie China

Phone +86 21 53852570
Fax +86 21 53852569

Genie Malaysia

Phone +60 4 228 1235
Fax +60 4 226 6872

Genie Japan

Phone +81 3 3453 6082
Fax +81 3 3453 6083

Genie Korea

Phone +82 2 558 7267
Fax +82 2 558 3910

Genie Africa

Phone +27 11 455 0373
Fax +27 11 455 0355

Genie Latin America

Phone +55 11 4055 2499
Fax +55 11 4043 1661

Distributed By: